

# Industrial Grade **Turbine Housing**

---

## Owner's Manual

Includes Aluminum, Brass and Stainless Steel  
Housings and ANSI Flange Fittings

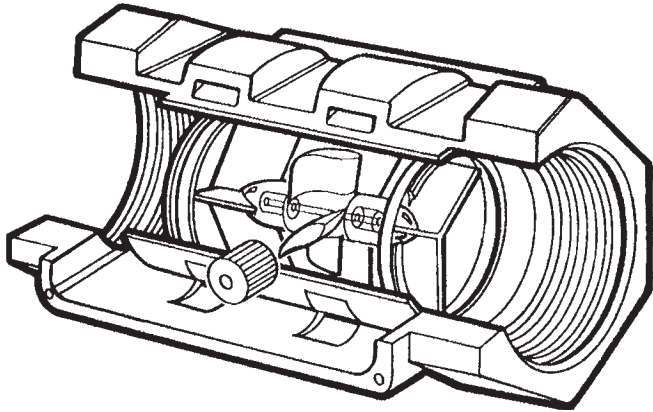

5252 East 36th Street North  
Wichita, KS USA 67220-3205  
TEL: 316-686-7361  
FAX: 316-686-6746

---

***GREAT PLAINS INDUSTRIES, INC.***

"A Great Plains Ventures Subsidiary"

[www.gpimeters.net](http://www.gpimeters.net)

**1-888-996-3837**

**To the owner...**

Congratulations on receiving your GPI Industrial Grade Turbine. We are pleased to provide you with a product designed to give you maximum reliability and efficiency.

Our business is the design, manufacture, and marketing of liquid handling, agricultural, and recreational products. We succeed because we provide customers with innovative, reliable, safe, timely, and competitively-priced products. We pride ourselves in conducting our business with integrity and professionalism.

We are proud to provide you with a quality product and the support you need to obtain years of safe, dependable service.

President  
Great Plains Industries, Inc.

**TABLE OF CONTENTS**

- General Information..... 2
- Installation ..... 4
- Operation..... 6
- Maintenance ..... 6
- Troubleshooting..... 8
- Model Number Chart ..... 8
- Specifications ..... 9
  - Aluminum ..... 9
  - Brass..... 11
  - Stainless Steel ..... 13
  - Flange Fittings ..... 15
- Illustrated Parts Drawing ..... 17
- Service..... 18

**GENERAL INFORMATION**

This manual will assist you in installing and maintaining your GPI Industrial Grade turbine housing. (See Figure 1) Information on computer electronics and accessory modules are contained in other manuals. Please reference those as necessary.

**Figure 1**

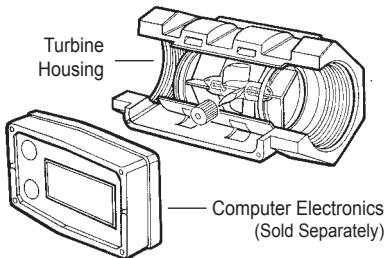

For best results, take the time to fully acquaint yourself with all information about all components of your GPI Electronic Digital Metering System prior to installation and use. If you need assistance, contact the distributor from whom you purchased your turbine.



This symbol is used throughout the manual to call your attention to safety messages.

**WARNING**

**Warnings** alert you to the potential for personal injury.

**CAUTION**

**Cautions** call your attention to practices or procedures which may damage your equipment.

**NOTES** give information that can improve efficiency of operations.

It is your responsibility to make sure that all operators have access to adequate instructions about safe operating and maintenance procedures.

## Read Me!

For your safety, review the major warnings and cautions below before operating your equipment.

### **⚠ WARNING**

The apparatus enclosure may contain aluminum and is considered to constitute a potential risk of ignition by impact or friction. Care must be taken into account during installation and use to prevent impact or friction.

### **⚠ WARNING**

Part of the enclosure is constructed from plastic. To prevent the risk of electrostatic sparking the plastic surface should only be cleaned with a damp cloth.

1. Use **only fluids** that are compatible with the housing material and wetted components of your turbine.
2. When measuring flammable liquids, observe precautions against fire or explosion.
3. When handling hazardous liquids, always follow the liquid manufacturer's safety precautions.
4. When working in hazardous environments, always exercise appropriate safety precautions.
5. Always dispose of used cleaning solvents in a safe manner according to the solvent manufacturer's instructions.

6. During turbine removal, liquid may spill. Follow the liquid manufacturer's safety precautions for clean up of minor spills.
7. Do not blow compressed air through the turbine.
8. Do not allow liquids to dry inside the turbine.
9. Handle the rotor carefully. Even small scratches or nicks can affect accuracy.
10. When tightening the turbine, use a wrench only on the wrench flats.
11. For best results, always verify accuracy before use.

## Product Description

GPI Industrial Meter Turbines are identified by the internal diameter of the inlet and outlet.

- Model 05 – 1/2 inch
- Model 07 – 3/4 inch
- Model 10 – 1 inch
- Model 15 – 1-1/2 inch
- Model 20 – 2 inch

Each turbine is designed to work with onboard computer electronics and/or with one of several accessory output modules.

Liquid flows through the turbine housing causing an internal rotor to spin. As the rotor spins, an electrical signal is generated in the pickup coil. This signal is converted into engineering units (gallons, litres, etc.) on the local display. Accessory modules can be used to export the signal to other equipment.

Upon receipt, examine your meter for visible damage. The turbine is a precision measuring instrument and should be handled as such. Remove the protective plugs and caps for a thorough inspection. If any items are damaged or missing, contact your distributor.

Make sure the turbine model meets your specific needs. Refer to the Specifications Section and confirm the following:

1. The flowrate is within the limits of your model.
2. The liquid is compatible with the turbine's wetted components.
3. The system's pressure does not exceed the turbine's maximum pressure rating.

Information specific to your particular turbine, including serial number, model number, manufacturing date, and K-factor is etched on the meter. Be prepared to provide this information if you call customer service.

**SN = Serial Number**, a 6-digit number that identifies this particular turbine.

**MODEL = Model Number** begins with a letter indicating the housing material.

- A** for Aluminum
- B** for Brass
- H** for Stainless Steel High Pressure
- S** for Stainless Steel

Two digits follow the material code indicating the size.

- 05 – 1/2 inch
- 07 – 3/4 inch
- 10 – 1 inch
- 15 – 1-1/2 inch
- 20 – 2 inch

The final letter indicates the type of thread.

- F** for Flange
- N** for NPT
- I** for ISO

**MFG DATE = Manufacturing Date** indicating the week and year of manufacture.

**KF = K-Factor** given in pulses per gallon (PPG).

For your future reference, it might be useful to record this information in the manual in case it becomes unreadable on the turbine.

## INSTALLATION

All GPI turbines are designed to measure flow in only one direction. The direction is indicated by the arrow, cast-molded in the turbine. If the computer display is upside down, remove the four screws, turn the display 180 degrees and reinstall the screws. See Diagram 1.

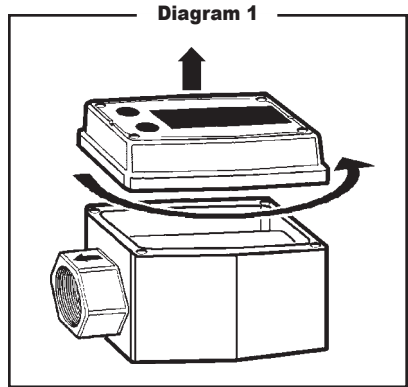

Flow altering devices such as elbows, valves, and reducers can affect accuracy. See Diagram 2. The following recommended guidelines are given to enhance accuracy and maximize performance. Distances given here are minimum requirements; double them for desired straight pipe lengths.

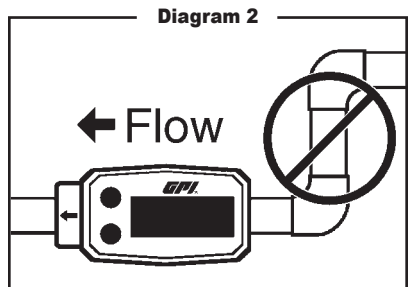

Upstream from the turbine, allow a minimum straight pipe length at least 10 times the internal diameter of the turbine. For example, with the 1 inch turbine, there should be 10 inches (25.4 cm) of straight pipe immediately upstream. The desired upstream straight pipe length is 20 inches (50.8 cm).

Downstream from the turbine, allow a minimum straight pipe length at least 5 times the internal diameter of your turbine. For example, with the 1 inch turbine, there should be 5 inches (12.7 cm) of straight pipe immediately downstream. The minimum downstream distance is 10 inches (25.4 cm). See Diagram 3.

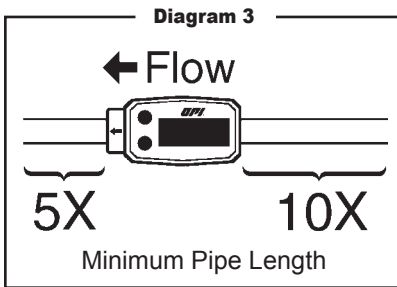

A typical back pressure of 5 to 50 PSI (0.34 to 3.4 bar) will prevent cavitation. Create back pressure by installing a control valve on the downstream side of the meter at the proper distance detailed above.

Foreign material in the liquid being measured can clog the turbine's rotor and adversely affect accuracy. If this problem is anticipated or experienced, install screens to filter impurities from incoming liquids.

**Models 1/2 in., 3/4 in. and 1 in.:**

Maximum Particulate Size	
Inches:	0.005
Microns:	125
Mesh:	55
Standard Sieve:	125 $\mu$ m
Alternative Sieve:	No. 120

**Models 1-1/2 in. and 2 in.:**

Maximum Particulate Size	
Inches:	0.018
Microns:	500
Mesh:	28
Standard Sieve:	500 $\mu$ m
Alternative Sieve:	No. 35

To ensure accurate measurement, remove all air from the system before use.

Each turbine contains a removable back coverplate. Leave the coverplate installed unless accessory modules specify removal.

**Connections**

1. To protect against leakage, seal all threads with an appropriate sealing compound. Make sure the sealing compound does not intrude into the flow path.
2. Make sure the arrow on the outlet is pointed in the direction of the flow.
3. Tighten the turbine onto the fittings. Use a wrench only on wrench flats.

**NOTE:** If connecting to new male threads, burrs and curls can adversely effect accuracy. Correct the problem prior to turbine installation.

Verify accuracy after connections are complete. See Operation section.

**Flange Connection**

Use a gasket between the meter flange and mating flange. Determine the material of the gasket based on the operating conditions and type of fluid.

**NOTE:** Do not over tighten the flange bolts. This may cause the gasket to be compressed into the flow stream and may decrease the accuracy of the meter.

## OPERATION

### Verify Accuracy

Before use, check the turbine's accuracy and verify calibration.

1. Make sure there is no air in the system.
2. Measure an exact known volume into an accurate container.
3. Verify the volume against the readout or recording equipment.

NOTE: If necessary, use a correction factor to figure final volume.

For best results, accuracy should be verified periodically as part of a routine maintenance schedule.

## MAINTENANCE

### Remove the Turbine

#### ⚠ WARNING

During turbine removal, liquid may spill. Follow the liquid manufacturer's safety precautions for clean up of minor spills.

1. Drain all liquid from the turbine. Wear protective clothing as necessary.
2. Loosen both ends of the turbine. Use a wrench only on the turbine's wrench flats.
3. If the turbine is not immediately installed again, cap lines as necessary.

### Clean the Turbine

During use, the turbine should be kept full of liquid to ensure that drying does not occur inside the turbine. If drying or caking should occur, the rotor will stick or drag, affecting accuracy. To determine if the rotor is

stuck or dragging, gently blow air through the meter and listen for the quiet whir of the rotor.

#### ⚠ CAUTION

Never blow compressed air through the meter. It could damage the rotor.

1. Remove the turbine from the system following the directions below.
2. Carefully clean residue off all parts. Remove internal parts as detailed above. Note orientation carefully for correct assembly. Internal parts can be soaked for 10 to 15 minutes in compatible cleaning solutions. Use a soft brush or small probe to *carefully* remove residue from the rotor.

#### ⚠ WARNING

Follow the liquid manufacturer's instructions for the disposal of contaminated cleaning solvents.

3. When the rotor turns freely, assemble and install it again following the instructions above.
4. Check accuracy after cleaning. See Diagram 4 for example of bucket test method.

Diagram 4

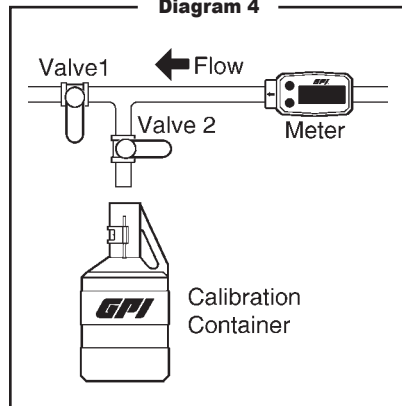

## Replace Internal Parts

1. Remove the turbine from the system as detailed above.

NOTE: Carefully notice the orientation of all internal parts as they are removed, especially the orientation of the rotor to the flow direction arrow. See Figure 2.

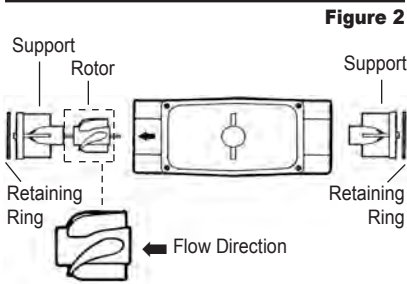

Figure 2

2. Using a small tool such as a screwdriver or awl, gently pry one retaining ring from its groove. Remove the support. If necessary, use needle nose pliers. Little or no force should be required.
3. Carefully remove the rotor.

### **CAUTION**

**Handle the rotor carefully. Even small scratches or nicks can affect accuracy.**

4. Turn the turbine over and remove the other retaining ring. Remove the other support.
5. Clean, as detailed below, or discard as necessary.
6. Replace one support and retaining ring. Parts should drop easily into place with little or no force.
7. Install the rotor. Make sure the wide end of the rotor's blades faces the flow direction. See Figure 3.

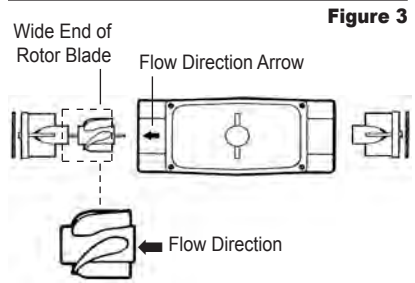

Figure 3

8. Turn the turbine over and drop the second support into place. Put the final retaining ring into position.
9. Reinstall the turbine, purge the system of air, and verify accuracy before use.

## TROUBLESHOOTING

<b>Symptom</b>	<b>Probable Cause</b>	<b>Solution</b>
A. MEASUREMENT IS NOT ACCURATE	1. Turbine operated below minimum rate	Increase flowrate. See Specifications.
	2. Turbine partially clogged with dried liquid	Remove turbine. Clean carefully. Make sure rotor spins freely.
	3. Turbine bearings partially clogged with dried liquid	Remove turbine. Clean carefully. Make sure rotor spins freely.
	4. Sealant wrapped around rotor	Remove turbine. Clear material from rotor. Make sure rotor spins freely.
	5. Installed too close to fittings	Install correctly. See Installation Section.
	6. Improper connections to recording device	Check all electrical connections. Reference appropriate installation instructions.
	7. Accuracy needs verification	Complete normal accuracy verification procedures. Repeat periodically.

## MODEL NUMBER CHART

<b>Normal Range GPM Water</b>	<b>Normal Range LPM Water</b>	<b>Inlet / Outlet Size NPT</b>	<b>Aluminum</b>	<b>Brass</b>	<b>Stainless Steel</b>	<b>Stainless Steel High Pressure</b>
1 - 10	3.8 - 37.9	1/2 in.	A05	B05	S05	H05
2 - 20	7.6 - 75.7	3/4 in.	A07	B07	S07	H07
5 - 50	18.9 - 190	1 in.	A10	B10	S10	H10
10 - 100	38 - 380	1-1/2 in.	A15	B15	S15	H15
20 - 200	76 - 760	2 in.	A20	B20	S20	H20



## SPECIFICATIONS – ALUMINUM

All data on Models 1/2 inch, 3/4 inch, and 1 inch determined with 1 centipoise solvent test fluid at 70° F (21° C). Data on Models 1-1/2 inch and 2 inch is determined with water at 70° F (21° C).

Model Size	1/2 in.	3/4 in.	1 in.	1-1/2 in.	2 in.
Linear Flow Range					
Gallons/minute (GPM)	1-10	2-20	5-50	10-100	20-200
Litres/minute (LPM)	3.8-37.9	7.6-75.7	18.9-190	38-380	76-760
Maximum Flow <sup>1</sup>					
Gallons/minute (GPM)	15	30	75	150	300
Litres/minute (LPM)	56.8	113.6	284	568	1,136
Maximum Pressure Drop in 10:1 Range					
PSIG	8	6	10	4	7
bar	0.55	0.5	0.34	0.28	0.28
Frequency Range in Linear Flow Range	42-420 Hz	37-370 Hz	47-470 Hz	36-360 Hz	33-330 Hz
Connections					
NPT or ISO Threads	Yes	Yes	Yes	Yes	Yes
Female	Yes	Yes	Yes	Yes	Yes
Inlet/Outlet Size	1/2 in.	3/4 in.	1 in.	1-1/2 in.	2 in.
Wrench Size:					
Inch	1-1/16 in.	1-5/16 in.	1-5/8 in.	2-3/8 in.	3 in.
Millimeter	27 mm	33 mm	41 mm	60 mm	75 mm
Weight*					
Pounds	0.6 lbs.	0.7 lbs.	0.8 lbs.	2.0 lbs.	3.1 lbs.
Kilograms	0.8 kg	1.0 kg	1.1 kg	1.8 kg	2.9 kg

\* Computer electronics add 0.2 lbs. (0.1kg) to total weight.

<sup>1</sup> The meter can operate up to this flowrate without damage. Continuous operation will severely degrade meter life and performance.

### Performance

Linear Range for 1/2 in.: 10:1 @ ±2.0% of reading  
 Linear Range for 3/4 in. and 1 in.: 10:1 @ ±1.5% of reading  
 Linear Range for 1-1/2 in. and 2 in.: 10:1 @ ±1.0% of reading  
 Repeatability: ±0.1%

### Pressure Rating

300 PSIG (21 bar)

### Wetted Components

Housing: Aluminum  
 Journal Bearings: Ceramic (96% Alumina)  
 Shaft: Tungsten Carbide  
 Rotor and Supports: PVDF  
 Retaining Rings: 316 Stainless Steel

### Temperature Range

-40° F to +250° F (-40° C to +121° C)

These temperatures apply to operations and storage. They are only for the turbine without computer electronics. Final operational temperature range is determined by computer electronics or accessory modules.

# Dimensions

Model Size	1/2 in.	3/4 in.	1 in.	1-1/2 in.	2 in.
<b>A = Height:</b>					
Inches	1.8 in.	2.0 in.	2.2 in.	2.8 in.	3.2 in.
Centimeters	4.6 cm	5.1 cm	5.6 cm	7.1 cm	8.2 cm
<b>B = Width</b>					
Inches	2.0 in.	2.0 in.	2.0 in.	2.7 in.	3.3 in.
Centimeters	5.1 cm	5.1 cm	5.1 cm	6.9 cm	8.4 cm
<b>C = Length</b>					
Inches	4.2 in.	4.3 in.	4.5 in.	5.3 in.	6.3 in.
Centimeters	10.7 cm	10.9 cm	11.4 cm	13.5 cm	16.0 cm

Computer electronics add 0.7 in. (1.8 cm) to height of turbine.

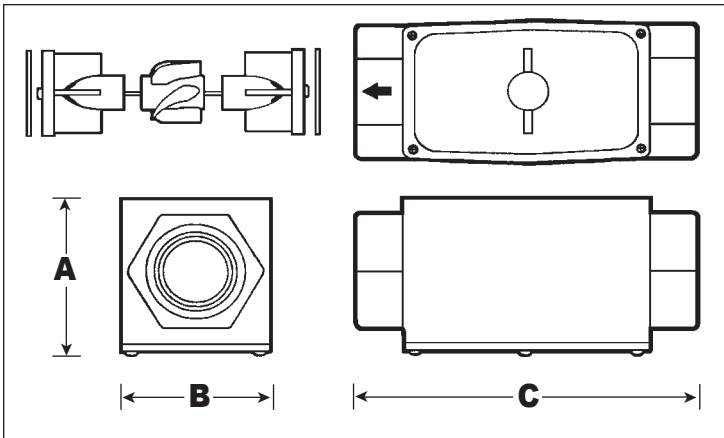

## SPECIFICATIONS – BRASS

All data on Models 1/2 inch, 3/4 inch, and 1 inch determined with 1 centipoise solvent test fluid at 70° F (21° C). Data on Models 1-1/2 inch and 2 inch is determined with water at 70° F (21° C).

Model Size	1/2 in.	3/4 in.	1 in.	1-1/2 in.	2 in.
Linear Flow Range					
Gallons/minute (GPM)	1-10	2-20	5-50	10-100	20-200
Litres/minute (LPM)	3.8-37.9	7.6-75.7	18.9-190	38-380	76-760
Maximum Flow <sup>1</sup>					
Gallons/minute (GPM)	15	30	75	150	300
Litres/minute (LPM)	56.8	113.6	284	568	1,136
Maximum Pressure Drop in 10:1 Range					
PSIG	8	6	10	4	7
bar	0.55	0.5	0.34	0.28	0.28
Frequency Range in Linear Flow Range	42-420 Hz	37-370 Hz	47-470 Hz	36-360 Hz	33-330 Hz
Connections					
NPT or ISO Threads	Yes	Yes	Yes	Yes	Yes
Female	Yes	Yes	Yes	Yes	Yes
Inlet/Outlet Size	1/2 in.	3/4 in.	1 in.	1-1/2 in.	2 in.
Wrench Size:					
Inch	1-1/16 in.	1-5/16 in.	1-5/8 in.	2-3/8 in.	3 in.
Millimeter	27 mm	33 mm	41 mm	60 mm	75 mm
Weight*					
Pounds	2.0 lbs.	2.3 lbs.	2.7 lbs.	6.0 lbs.	9.6 lbs.
Kilograms	0.9 kg	1.0 kg	1.2 kg	2.7 kg	4.3 kg

\* Computer electronics add 0.2 lbs. (0.1 kg) to total weight.

<sup>1</sup> The meter can operate up to this flowrate without damage. Continuous operation will severely degrade meter life and performance.

### Performance

Linear Range for 1/2 in.: 10:1 @ ±2.0% of reading  
 Linear Range for 3/4 in. and 1 in.: 10:1 @ ±1.5% of reading  
 Linear Range for 1-1/2 in. and 2 in.: 10:1 @ ±1.0% of reading  
 Repeatability: ±0.1%

### Pressure Rating

300 PSIG (21 bar)

### Wetted Components

Housing: Brass  
 Journal Bearings: Ceramic (96% Alumina)  
 Shaft: Tungsten Carbide  
 Rotor and Supports: PVDF  
 Retaining Rings: 316 Stainless Steel

### Temperature Range

-40° F to +250° F (-40° C to +121° C)

These temperatures apply to operations and storage. They are only for the turbine without computer electronics. Final operational temperature range is determined by computer electronics or accessory modules.

# Dimensions

Model Size	1/2 in.	3/4 in.	1 in.	1-1/2 in.	2 in.
<b>A = Height:</b>					
Inches	1.8 in.	2.0 in.	2.2 in.	2.8 in.	3.2 in.
Centimeters	4.6 cm	5.1 cm	5.6 cm	7.1 cm	8.2 cm
<b>B = Width</b>					
Inches	2.0 in.	2.0 in.	2.0 in.	2.7 in.	3.3 in.
Centimeters	5.1 cm	5.1 cm	5.1 cm	6.9 cm	8.4 cm
<b>C = Length</b>					
Inches	4.2 in.	4.3 in.	4.5 in.	5.3 in.	6.3 in.
Centimeters	10.7 cm	10.9 cm	11.4 cm	13.5 cm	16.0 cm

Computer electronics add 0.7 in. (1.8 cm) to height of turbine.

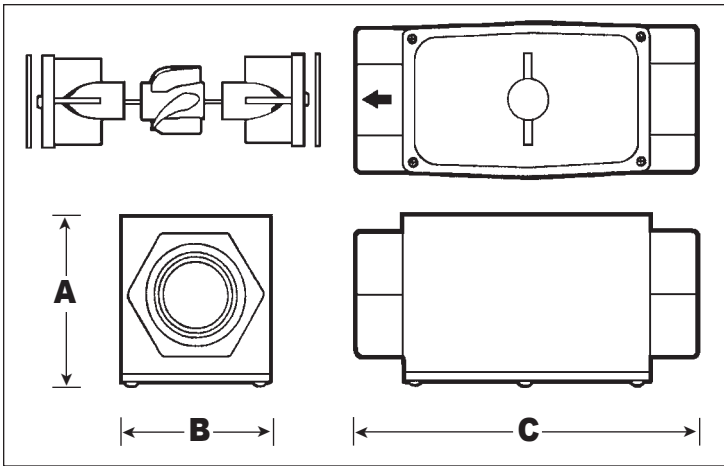

## SPECIFICATIONS – STAINLESS STEEL

All data on Models 1/2 inch, 3/4 inch, and 1 inch determined with 1 centipoise solvent test fluid at 70° F (21° C). Data on Models 1-1/2 inch and 2 inch is determined with water at 70° F (21° C).

Model Size	1/2 in.	3/4 in.	1 in.	1-1/2 in.	2 in.
Linear Flow Range					
Gallons/minute (GPM)	1-10	2-20	5-50	10-100	20-200
Litres/minute (LPM)	3.8-37.9	7.6-75.7	18.9-190	38-380	76-760
Maximum Flow <sup>1</sup>					
Gallons/minute (GPM)	15	30	75	150	300
Litres/minute (LPM)	56.8	113.6	284	568	1,136
Maximum Pressure Drop in 10:1 Range					
PSIG	8	6	10	4	7
bar	0.55	0.5	0.34	0.28	0.28
Frequency Range in Linear Flow Range	42-420 Hz	37-370 Hz	47-470 Hz	36-360 Hz	33-330 Hz
Connections					
NPT or ISO Threads	Yes	Yes	Yes	Yes	Yes
Female	Yes	Yes	Yes	Yes	Yes
Inlet/Outlet Size	1/2 in.	3/4 in.	1 in.	1-1/2 in.	2 in.
Wrench Size:					
Inch	1-1/16 in.	1-5/16 in.	1-5/8 in.	2-3/8 in.	3 in.
Millimeter	27 mm	33 mm	41 mm	60 mm	75 mm
Weight*					
Pounds	1.8 lbs.	2.0 lbs.	2.4 lbs.	4.0 lbs.	6.3 lbs.
Kilograms	0.8 kg	1.0 kg	1.1 kg	1.8 kg	2.9 kg

\* Computer electronics add 0.2 lbs. (0.1 kg) to total weight.

<sup>1</sup> The meter can operate up to this flowrate without damage. Continuous operation will severely degrade meter life and performance.

### Performance

Linear Range for 1/2 in.: 10:1 @ ±2.0% of reading

Linear Range for 3/4 in. and 1 in.: 10:1 @ ±1.5% of reading

Linear Range for 1-1/2 in. and 2 in.: 10:1 @ ±1.0% of reading

Repeatability: ±0.1%

**Pressure Rating** 1,500 PSIG (102 bar) – Standard Stainless Steel Meter  
3,000 PSIG (207 bar) – High Pressure Stainless Steel Meter

### Wetted Components

Housing: 316 Stainless Steel

Journal Bearings: Ceramic (96% Alumina)

Shaft: Tungsten Carbide

Rotor and Supports: PVDF

Retaining Rings: 316 Stainless Steel

### Temperature Range

-40° F to +250° F (-40° C to +121° C)

These temperatures apply to operations and storage. They are only for the turbine without computer electronics. Final operational temperature range is determined by computer electronics or accessory modules.

## Dimensions

Model Size	1/2 in.	3/4 in.	1 in.	1-1/2 in.	2 in.
<b>A = Height:</b>					
Inches	1.8 in.	2.0 in.	2.2 in.	2.8 in.	3.2 in.
Centimeters	4.6 cm	5.1 cm	5.6 cm	7.1 cm	8.2 cm
<b>B = Width</b>					
Inches	2.0 in.	2.0 in.	2.0 in.	2.7 in.	3.3 in.
Centimeters	5.1 cm	5.1 cm	5.1 cm	6.9 cm	8.4 cm
<b>C = Length</b>					
Inches	4.2 in.	4.3 in.	4.5 in.	5.3 in.	6.3 in.
Centimeters	10.7 cm	10.9 cm	11.4 cm	13.5 cm	16.0 cm

Computer electronics add 0.7 in. (1.8 cm) to height of turbine.

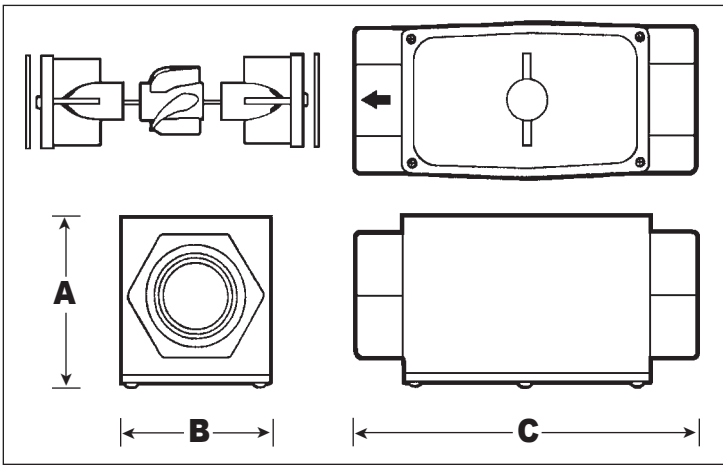

## SPECIFICATIONS – FLANGE FITTINGS

All data on Model 1 inch determined with 1 centipoise solvent test fluid at 70° F (21° C). Data on Models 1-1/2 inch and 2 inch is determined with water at 70° F (21° C).

Model Size	1 in.	1-1/2 in.	2 in.
Linear Flow Range			
Gallons/minute (GPM)	5-50	10-100	20-200
Litres/minute (LPM)	18.9-190	38-380	76-760
Maximum Flow <sup>1</sup>			
Gallons/minute (GPM)	75	150	300
Litres/minute (LPM)	284	568	1,136
Maximum Pressure Drop in 10:1 Range			
PSIG	10	4	7
bar	0.34	0.28	0.28
Frequency Range in Linear Flow Range	47-470 Hz	36-360 Hz	33-330 Hz
Connections			
ANSI 150 lb. Flange Bolt Size	Yes 1/2 in.	Yes 1/2 in.	Yes 5/8 in.
Weight*			
Pounds	6.5 lbs.	10.6 lbs.	17.9 lbs.
Kilograms	2.9 kg	4.8 kg	8.1 kg

\* Computer electronics add 0.2 lbs. (0.1 kg) to total weight.

<sup>1</sup> The meter can operate up to this flowrate without damage. Continuous operation will severely degrade meter life and performance.

### Performance

Linear Range for 1 in.: 10:1 @ ±1.5% of reading  
 Linear Range for 1-1/2 in. and 2 in.: 10:1 @ ±1.0% of reading  
 Repeatability: ±0.1%

**Pressure Rating** Flange Rule

### Wetted Components

Housing: 316 Stainless Steel  
 Journal Bearings: Ceramic (96% Alumina)  
 Shaft: Tungsten Carbide  
 Rotor and Supports: PVDF  
 Retaining Rings: 316 Stainless Steel

**Temperature Range** -40° F to +250° F (-40° C to +121° C)

These temperatures apply to operations and storage. They are only for the turbine without computer electronics. Final operational temperature range is determined by computer electronics or accessory modules.

# Dimensions

Model Size	1 in.	1-1/2 in.	2 in.
<b>A = Length:</b>			
Inches	6.75 in.	8.00 in.	9.50 in.
Centimeters	17.14 cm	20.32 cm	24.13 cm
<b>B = Width</b>			
Inches	4.25 in.	5.00 in.	6.00 in.
Centimeters	10.80 cm	12.71 cm	15.24 cm

Computer electronics add 0.7 in. (1.8 cm) to height of turbine.

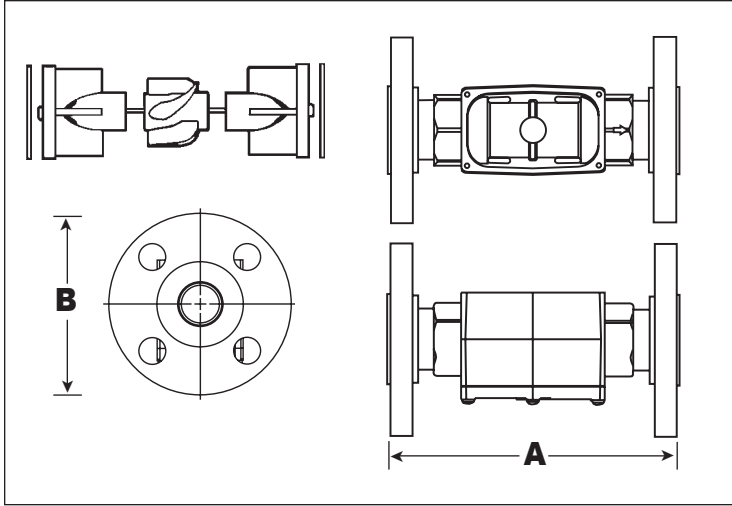



# ILLUSTRATED PARTS DRAWING

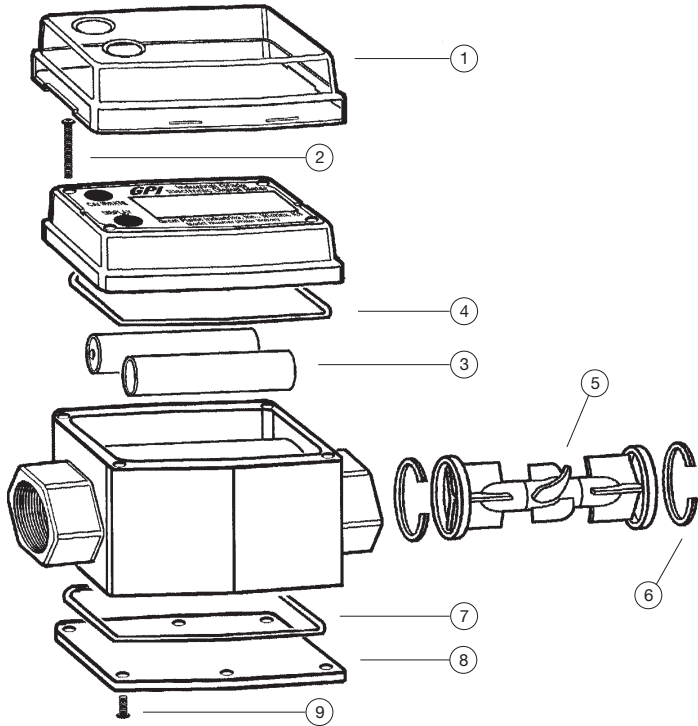

Item No.	Part No.	Description	No. Req'd.
1	906004-85	EDM Cover Single Access Port (optional) - Fits 1/2 in., 3/4 in. and 1 in. only .....	1
	906004-86	EDM Cover Dual Access Port (optional) - Fits 1/2 in., 3/4 in. and 1 in. only .....	1
2	904004-12	Screw .....	4
3	113520-1	Battery Kit (2 batteries included).....	1
4	901002-52	Seal, Computer.....	1
5	125500-1	"05" 1/2-inch Rotor/Support Replacement Kit (includes rotor assembly, support assembly & retaining rings) .....	1
	125500-2	"07" 3/4-inch Rotor/Support Replacement Kit (includes rotor assembly, support assembly & retaining rings) .....	1
	125500-3	"10" 1-inch Rotor/Support Replacement Kit (includes rotor assembly, support assembly & retaining rings) .....	1
	125500-4	"15" 1-1/2-inch Rotor/Support Replacement Kit (includes rotor assembly, support assembly & retaining rings) .....	1
	125500-5	"20" 2-inch Rotor/Support Replacement Kit (includes rotor assembly, support assembly & retaining rings) .....	1

Item No.	Part No.	Description	No. Req'd.
6	904005-20	One 05 - 1/2-inch Retaining Ring.....	2
	904005-21	One 07 - 3/4-inch Retaining Ring.....	2
	904005-22	One 10 - 1-inch Retaining Ring.....	2
	904005-23	One 15 - 1-1/2-inch Retaining Ring .....	2
	904005-24	One 20 - 2-inch Retaining Ring.....	2
	125505-01	Flange Gasket Kit with 2 Gaskets (1 in. Neoprene) (not shown) .....	1
125504-01	Flange Gasket Kit with 2 Gaskets (1 in. FKM) (not shown) .....	1	
125505-02	Flange Gasket Kit with 2 Gaskets (1-1/2 in. Neoprene) (not shown) .....	1	
125504-02	Flange Gasket Kit with 2 Gaskets (1-1/2 in. FKM) (not shown) .....	1	
125505-03	Flange Gasket Kit with 2 Gaskets (2 in. Neoprene) (not shown) .....	1	
125504-03	Flange Gasket Kit with 2 Gaskets (2 in. FKM) (not shown) .....	1	
7	901003-1	Back Coverplate O-Ring.....	1
8	125015-2	Back Coverplate .....	1
9	904005-13	Back Coverplate Screws.....	6

## SERVICE

For warranty consideration, parts, or other service information, please contact your local distributor. If you need further assistance, call the GPI Customer Service Department in Wichita, Kansas, during normal business hours.

**1-888-996-3837**

To obtain prompt, efficient service, always be prepared with the following information:

1. The model number of your turbine.
2. The serial number or manufacturing date code of your turbine.
3. Specific information about part numbers and descriptions.

For warranty work always be prepared with your original sales slip or other evidence of purchase date.

## Returning Parts

Please contact the factory before returning any parts. It may be possible to diagnose the trouble and identify needed parts in a telephone call. GPI can also inform you of any special handling requirements you will need to follow covering the transportation and handling of equipment which has been used to transfer hazardous or flammable liquids.

### **⚠ CAUTION**

Do not return turbines without specific authority from the GPI Customer Service Department. Due to strict regulations governing transportation, handling, and disposal of hazardous or flammable liquids, GPI will not accept turbines for rework unless they are completely free of liquid residue.

### **⚠ CAUTION**

Turbines not flushed before shipment can be refused and returned to the sender.



## Limited Warranty Policy

Great Plains Industries, Inc. 5252 E. 36<sup>th</sup> Street North, Wichita, KS USA 67220-3205, hereby provides a limited warranty against defects in material and workmanship on all products manufactured by Great Plains Industries, Inc. This product includes a 1 year warranty. Manufacturer's sole obligation under the foregoing warranties will be limited to either, at Manufacturer's option, replacing or repairing defective Goods (subject to limitations hereinafter provided) or refunding the purchase price for such Goods theretofore paid by the Buyer, and Buyer's exclusive remedy for breach of any such warranties will be enforcement of such obligations of Manufacturer. The warranty shall extend to the purchaser of this product and to any person to whom such product is transferred during the warranty period.

The warranty period shall begin on the date of manufacture or on the date of purchase with an original sales receipt. This warranty shall not apply if:

- A. the product has been altered or modified outside the warrantor's duly appointed representative;
- B. the product has been subjected to neglect, misuse, abuse or damage or has been installed or operated other than in accordance with the manufacturer's operating instructions.

To make a claim against this warranty, contact the GPI Customer Service Department at 316-686-7361 or 888-996-3837. Or by mail at:

Great Plains Industries, Inc.  
5252 E. 36<sup>th</sup> St. North  
Wichita, KS, USA 67220-3205

The company shall, notify the customer to either send the product, transportation prepaid, to the company at its office in Wichita, Kansas, or to a duly authorized service center. The company shall perform all obligations imposed on it by the terms of this warranty within 60 days of receipt of the defective product.

**GREAT PLAINS INDUSTRIES, INC., EXCLUDES LIABILITY UNDER THIS WARRANTY FOR DIRECT, INDIRECT, INCIDENTAL AND CONSEQUENTIAL DAMAGES INCURRED IN THE USE OR LOSS OF USE OF THE PRODUCT WARRANTED HEREUNDER.**

The company herewith expressly disclaims any warranty of merchantability or fitness for any particular purpose other than for which it was designed.

This warranty gives you specific rights and you may also have other rights which vary from U.S. state to U.S. state.

Note: In compliance with MAGNUSON MOSS CONSUMER WARRANTY ACT – Part 702 (governs the resale availability of the warranty terms).



Factory Mutual Approved  
Intrinsically Safe for Class I, II, III, Division 1, All Groups.



5252 East 36th Street North  
Wichita, KS USA 67220-3205  
TEL: 316-686-7361  
FAX: 316-686-6746

***GREAT PLAINS INDUSTRIES, INC.***

*"A Great Plains Ventures Subsidiary"*

[www.gpimeters.net](http://www.gpimeters.net)

**1-888-996-3837**