

NPT Meter
(1/2 in. to 2 in.)
Shown with Display Mount Cover Plate
and Display

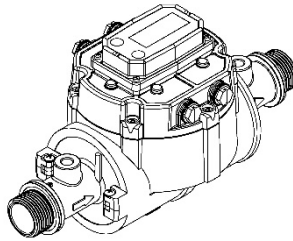

BSPM Meter
(1/2 in. to 2 in.)
Shown with Display Mount
Cover Plate and Display

ANSI Flanged Meter
(3 in. & 4 in.)
Shown with Plain Cover Plate
and Pulse Out Transmitter (QB)

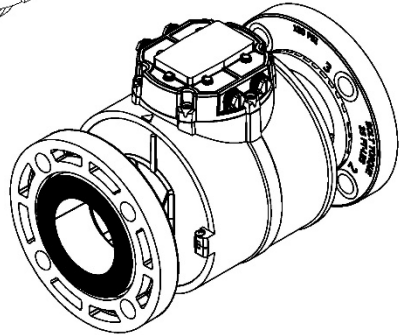

QSE SERIES ELECTROMAGNETIC METER



Please save these instruction for future reference. Read carefully before attempting to assemble, install, operate or maintain the product described.

Protect yourself and others by observing all safety information. Failure to comply with instructions could result in personal injury and/or property damage.

Please refer to back cover for information regarding this product's warranty and other important information.

DO NOT RETURN THIS PRODUCT TO THE STORE!

Please contact Great Plains Industries, Inc.® before returning any product. If you are missing parts, or experience problems with your installation, contact our Customer Support Department. We will be happy to assist you.

Call: 888-996-3837 or 316-686-7361

Email: meters@gplains.com

SAVE FOR YOUR RECORDS

Model #: _____

Serial #: _____

Purchase Date: _____

TABLE OF CONTENTS

Getting Started..... 4

General Safety Instructions..... 5

Specifications.....6

U.S. Measurement 7

Metric Measurement 8

U.S. Product Weight 9

Metric Product Weight 9

Dimensions 10

Temperatures 11

Fluid Electrical Conductivity 12

Meter Overview 13

Important Notice 13

Principle of Operation 13

Safety 14

Installation 14

Earth Ground 14

Process Fluid Grounding 14

Grounding Summary 14

Connections 17

Wiring 20

Troubleshooting..... 21

Maintenance & Service 22

Illustrated Replacement Parts List 23

Warranty 28

BEFORE YOU BEGIN

Usage

- This meter is CSA, NSF, CE and China RoHS approved and has an IP67 environmental rating.



Power Source Requirements

- This meter requires DC power. For this application, the power is provided by the customer power supply. See meter specifications section for detailed information.

UNPACKING



Inspect

- Upon receipt, examine your equipment for visible damage that may have occurred during shipment. If any items appear damaged or missing, contact your distributor.



- See General Safety Instruction, and all Cautions, Warnings, and Dangers as shown.

GENERAL SAFETY INSTRUCTIONS

IMPORTANT: It is your responsibility to:

- Ensure that all equipment operators have access to adequate instructions concerning safe operating and maintenance procedures.

⚠ CAUTION

This product is not approved for use with petroleum products (diesel fuel, unleaded gasoline, jet fuel, kerosene, etc.), aromatic hydrocarbons or other incompatible chemicals

⚠ CAUTION

This product is not approved for use in hazardous locations.

⚠ WARNING

When applying power, adhere to specifications listed in appropriate electronics manual.

⚠ CAUTION

Disconnect external power before attaching or detaching input or output wires.

⚠ WARNING

Compatibility of this product's material and the process fluid and/or environment should be considered prior to putting into service.

⚠ WARNING

Product should never be operated outside its published specifications for temperature or pressure. See specifications for your model.

⚠ WARNING

Make sure flow and pressure have been eliminated from process pipe prior to installing or removing product.

⚠ CAUTION

Installation near high electromagnetic fields and high current fields is not recommended and may result in inaccurate readings.

⚠ CAUTION

Do not allow water to freeze in meter. Ice expansion may burst the plastic housing.

⚠ CAUTION

Do not allow this meter to be used with steam.

SPECIFICATIONS

Design Type: Electromagnetic

INLET AND OUTLET	
NPT MODELS	
QSE05NPT	1/2 inch NPT
QSE07NPT	3/4 inch NPT
QSE10NPT	1 inch NPT
QSE15NPT	1-1/2 inch NPT
QSE20NPT	2 inch NPT
BSPP MODELS	
QSE05BSP	1/2 inch BSPP (ISO 228 - G 1/2)
QSE07BSP	3/4 inch BSPP (ISO 228 - G 3/4)
QSE10BSP	1 inch BSPP (ISO 228 - G 1)
QSE15BSP	1-1/2 inch BSPP (ISO 228 - G 1 1/2)
QSE20BSP	2 inch BSPP (ISO 228 - G 2)
ANSI FLANGE MODELS	
QSE30FAP	3 inch 150 # ANSI Flange (Polymer)
QSE40FAP	4 inch 150 # ANSI Flange (Polymer)

WETTED COMPONENTS	
Housing	NORYL™ GFN3 PPE+PS
Electrodes	316L Stainless Steel
Temperature Probes	316 Series Stainless Steel
Pipe Plugs	300 Series Stainless Steel
O-Rings	EPDM (Ethylene Propylene Diene Monomer)
MAXIMUM WORKING PRESSURE	
De-rate maximum working pressure 0.682 PSIG per each degree °F above 70° F	
NPT	150 PSIG @70° F 10.3 BAR @ 21° C
BSPP	150 PSIG @70° F 10.3 BAR @ 21° C
ANSI FLANGE	150 PSIG @70° F 10.3 BAR @ 21° C
POWER SUPPLY	
Voltage Requirement	Min. 12 VDC (Lower voltage will cause inaccurate readings)
	Max. 36 VDC (higher voltage may damage unit)
ELECTRICAL	
Pollution Degree	2
Installation Category	1
Altitude	2,000m Max.
IP67 rated enclosure. CSA approved for indoor use only	

See electronics manuals for
electronic specifications.

SPECIFICATIONS (Continued)

U.S. Measurement

Unit of Measure:		Gallon			
TURNDOWN		60:1			
ACCURACY					
Line Size	Flow Range (GPM)	ACCURACY	±Uncertainty		Typ. K-factor (PPG)
1/2 inch	0.16 to 10 gpm (.25 to 15 fps)	± 0.5% of Reading	± 0.023 fps	± .015 gpm	4347
3/4 inch	0.33 to 20 gpm (.25 to 15 fps)	± 0.5% of Reading	± 0.012 fps	± .015 gpm	1937
1 inch	0.67 to 40 gpm (.25 to 15 fps)	± 0.5% of Reading	± 0.006 fps	± .015 gpm	1089
1 1/2 Inch	1.33 to 80 gpm (.25 to 15 fps)	± 0.5% of Reading	± 0.003 fps	± .015 gpm	484.1
2 inch	2.5 to 150 gpm (.25 to 15 fps)	± 0.5% of Reading	± 0.003 fps	± .030 gpm	400
3 inch	5 to 300gpm (.25 to 15 fps)	± 0.5% of Reading	± 0.003 fps	± .060 gpm	121
4 inch	10 to 600gpm (.25 to 15 fps)	± 0.5% of Reading	± 0.003 fps	± .120 gpm	68.1
FLUID OPERATING TEMPERATURE:		+32° F to +180° F			
		(Do not allow fluid to freeze inside meter.)			
STORAGE TEMPERATURE:		-40° F to +228° F			
AMBIENT AIR OPERATING TEMPERATURE		0° F to +140° F ALL METERS			

There is a correlation between ambient air temperature and maximum fluid operating temperature:

- As ambient air temperature increases, the maximum fluid operating temperature decreases.

See Maximum Temperature Conditions graph named “TEMPERATURES” on page 11 to verify that your process is within allowable meter operating limits.

SPECIFICATIONS (Continued)

Metric Measurement

Unit of Measure:		Litre			
TURNDOWN		60:1			
ACCURACY					
Line Size	Flow Range (L/min)	ACCURACY	±Uncertainty		Typ. K-factor (PPL)
1/2 inch	0.63 to 38 L/min [.076 to 4.57 m/s]	± 0.5% of Reading	± 7.0 mm/s	± .057 L/min	1148.5
3/4 inch	1.27 to 76 L/min [.076 to 4.57 m/s]	± 0.5% of Reading	± 3.7 mm/s	± .057 L/min	511.8
1 inch	2.52 to 151 L/min [.076 to 4.57 m/s]	± 0.5% of Reading	± 2.0 mm/s	± .057 L/min	287.7
1 1/2 Inch	5.05 to 303 L/min [.076 to 4.57 m/s]	± 0.5% of Reading	± 1.0 mm/s	± .057 L/min	127.9
2 inch	9.47 to 568 L/min [.076 to 4.57 m/s]	± 0.5% of Reading	± 1.0 mm/s	± .114 L/min	105.7
3 inch	19 to 1140 L/min [.076 to 4.57 m/s]	± 0.5% of Reading	± 1.0 mm/s	± .227 L/min	30
4 inch	38 to 2270 L/min [.076 to 4.57 m/s]	± 0.5% of Reading	± 1.0 mm/s	± .454 L/min	18
FLUID OPERATING TEMPERATURE:		0° C to +82° C			
		(Do not allow fluid to freeze inside meter.)			
STORAGE TEMPERATURE:		-40° C to +108° C			
AMBIENT AIR OPERATING TEMPERATURE		-18° C to +60° C ALL METERS			

There is a correlation between ambient air temperature and maximum fluid operating temperature:

- As ambient air temperature increases, the maximum fluid operating temperature decreases.

See Maximum Temperature Conditions graph named “TEMPERATURES” on page 11 to verify that your process is within allowable meter operating limits.

SPECIFICATIONS (Continued)

U.S Product Weight

PRODUCT WEIGHT – lb:*		
	NPT / BSPP	ANSI Polymer Flange
1/2 in.	2.5	-
3/4 in.	2.6	-
1 in.	2.7	-
1 1/2 in.	3.9	-
2 in.	4.3	-
3 in.	-	14
4 in.	-	16.3

* Weight with display. For plain cover plates, subtract 0.2 lb.

Metric Product Weight

PRODUCT WEIGHT – kg:*		
	NPT / BSPP	ANSI Polymer Flange
1/2 in.	1.1	-
3/4 in.	1.2	-
1 in.	1.2	-
1 1/2 in.	1.8	-
2 in.	2.0	-
3 in.	-	6.4
4 in.	-	7.4

* Weight with display. For plain cover plates, subtract 0.09 kg.

SPECIFICATIONS (Continued)

Dimensions

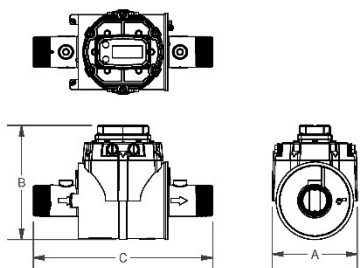

NPT / BSP WITH Q9 ELECTRONICS

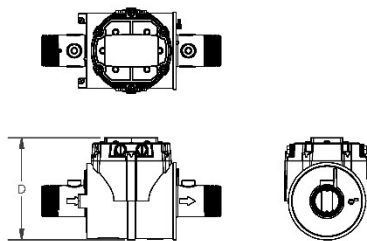

NPT / BSP WITH QB ELECTRONICS

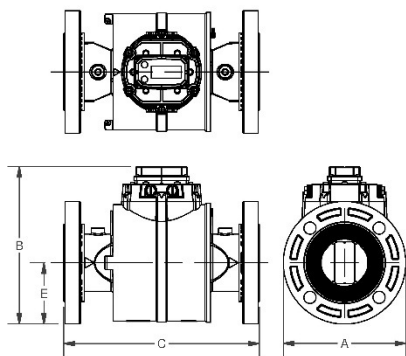

ANSI FLANGE WITH Q9 ELECTRONICS

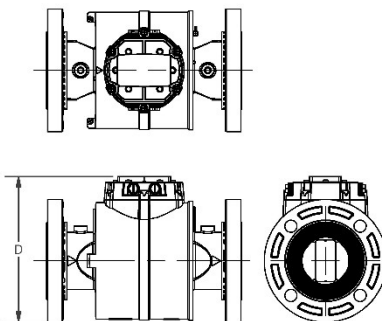

ANSI FLANGE WITH QB ELECTRONICS

QSE METER DIMENSIONS (NPT, BSPP, ANSI FLANGE)					
Listed in inches and Centimeters. Centimeters shown in [] brackets					
METER SIZE & FITTING	A	B	C	D	E
1/2 in. NPT & BSPP	5.20 [13.21]	5.85 [14.86]	10.50 [26.67]	5.13 [13.09]	1.83 [4.65]
3/4 in. NPT & BSPP	5.20 [13.21]	5.85 [14.86]	10.75 [27.31]	5.13 [13.09]	1.83 [4.65]
1 in. NPT & BSPP	5.20 [13.21]	5.85 [14.86]	11.00 [27.94]	5.13 [13.09]	1.83 [4.65]
1-1/2 in. NPT & BSPP	5.22 [13.26]	6.97 [17.70]	11.00 [27.94]	6.25 [15.88]	2.37 [6.02]
2 in. NPT & BSPP	5.22 [13.26]	6.97 [17.70]	11.00 [27.94]	6.25 [15.88]	2.37 [6.02]
3 in. ANSI Flange	7.50 [19.05]	9.64 [24.48]	12.00 [30.48]	8.92 [22.66]	3.75 [9.53]
4 in. ANSI Flange	9.00 [22.86]	10.39 [26.39]	12.00 [30.48]	9.67 [24.56]	4.50 [11.43]

* If 4-20 mA module is installed, add .90 [2.28] to height.

SPECIFICATIONS (Continued)

Temperatures

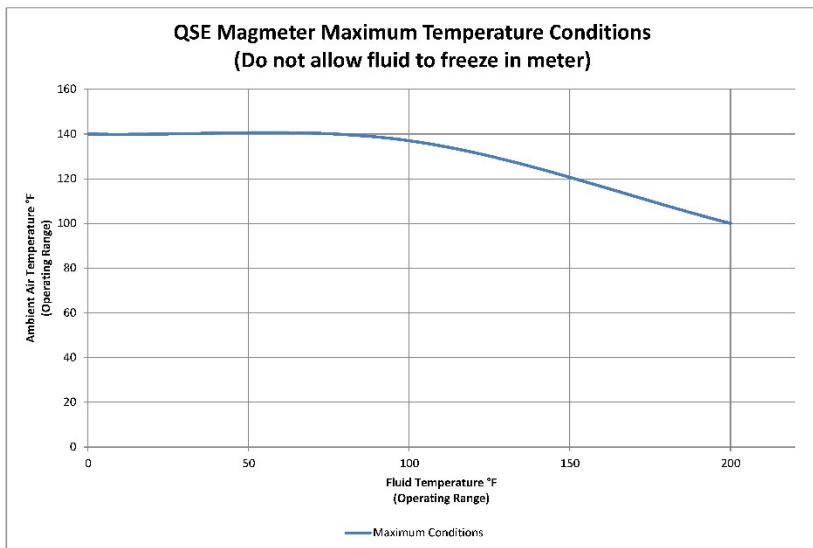

FLUID ELECTRICAL CONDUCTIVITY

Fluid Electrical Conductivity Reference:

The basic unit of fluid conductivity is “mho/cm”, otherwise known as 1 Siemen. However, this unit does not really occur in water, so we typically use one thousandth (milli-) or one millionths (micro-) of it for natural waters (1000 milimhos and 1,000,000 micromhos are equal to one mho).

The useful unit for seawater is milimhos/cm (mS/cm); seawater is around 55 mS/cm. The useful unit for freshwater is micromhos/cm (µmhos/cm, or µS/cm); tap water ranges between 50 and 800 µS/ cm (depending on the source).

Electrical Conductivity of Common Fluids

FLUID	TEMPERATURE (°F)	CONDUCTIVITY (µs/cm)
Coca Cola Syrup	68	600
Coffee Extract	183. 2	5000
Corn Syrup	89.6	16
Ethylene Glycol (Pure)	68	1.07
Gin 90 Proof	77	10
ISO-propyl Alcohol	77	3.5
Molasses	50	300
RC Cola Syrup	77	600
Sugar Solution Dilute	86	585
Urea	77	5000
Vodka 100 Proof	77	4
Water, Distilled	-	0.04
Water, NYC	77	72

NOTE: This table of fluid conductivity is for reference only, to show the relative conductivity of various fluids. Since the list contains flammable fluids, it is not to be construed as a list of permissible fluids to be used with QSE series meters.

NOTE: QSE series meters are for use with water, aqueous solutions and other non-flammable, electrically conductive fluids. Do not use the meter with petroleum products (diesel fuel, unleaded gasoline, jet fuel, kerosene, etc.) or other incompatible chemicals.

METER OVERVIEW

Introduction

The QSE meter has multiple types of output electronics available. The electronics for the operation of the meter coils and flow tube are housed within the meter body casing. The cover plate is designed in two versions; a plain cover plate or a display mount cover plate. The electronics (QB) and the choice of communications suites (QSI1, QSI2 or QSI3) are housed within the plain cover plate. A display (Q9) is also available mounted to the "display mount" cover plate.

All meters are equipped with galvanically isolated pulse-out electronics (QB) as the default standard, regardless of style of cover plate.

This manual contains overall information related only to the meter. This meter is externally powered and all external wiring connects to the electronics within the cover plate through its threaded ports.

The magnetic coils, electrodes and other electronic components within the main meter body receive power from the electronics housed within the cover plate through a ribbon cable. See the included electronics manuals for meter wiring diagrams specific to your meter electronics.

Important Notice

Your QSE meter is supplied ready for operation in a wide variety of applications. The meter has been factory configured to your order. It is suitable for volumetric flow measurement of non-flammable, electrically conductive liquids that have a minimum fluid conductivity of 10 $\mu\text{S}/\text{cm}$, and are compatible with the wetted components of the meter (See Specification Section).

Fluid conductivity below 50 $\mu\text{S}/\text{cm}$ may result in uncertain readings. Consult factory for use with fluids having a conductivity below 50 $\mu\text{S}/\text{cm}$.

Use QSE series meters with water, aqueous solutions and other non-flammable, electrically conductive fluids. A fluid conductivity chart of common liquids is in this manual for your reference. Do not use the meter with petroleum products (diesel fuel, unleaded gasoline, jet fuel, kerosene, etc.) or incompatible chemicals.

QSE series meters are very sensitive to electric noise if operated within 6 inches (15.2cm) of some electric motors, relays, transformers or other sources of electronic noise.

If the QSE series meters are used in a manner not specified by the manufacturer, the protection provided by the equipment may be impaired.

Principle of Operation

Faraday's Law of Electromagnetic Induction is the operating principle on which the QSE series meters are based. Faraday's Law (paraphrased) states that a voltage will be induced in a conductor when it passes through a magnetic field, and the induced voltage will be directly proportional to the velocity of the conductor passing through that magnetic field. In this case, flowing liquid is the conductor and the QSE meter creates the magnetic field.

The velocity of the flowing liquid, which must pass through the magnetic field, is the velocity of the conductor. A voltage is induced in the conductive liquid as it passes through the magnetic field. By placing electrodes in calculated locations on the flow tube of the meter, it is possible to accurately measure the induced voltage, thus determining the corresponding velocity and volumetric flow of the liquid.

METER OVERVIEW (Continued)

Safety

- This product is not approved for use with petroleum products (diesel fuel, unleaded gasoline, jet fuel, kerosene, etc.), aromatic hydrocarbons, flammable fluids or other incompatible chemicals
- This product is not approved for use in hazardous locations.
- Be sure O-rings and seals are kept in good repair.
- When applying power, adhere to specifications listed in appropriate electronics manual.
- Disconnect external power before attaching or detaching input or output wires.

INSTALLATION

Earth Ground

When making installations, the magnetic flow meter grounding rules have to be observed. The sensors of the QSE flow meter are sensitive to any electrical noise that is always present in piping systems. The fluid in piping systems usually carries significant levels of static electricity, and should be grounded for the QSE meter to be at its best performance.

As part of the installation, it is important to understand the importance of having the QSE meter connected to "earth ground". Earth grounding helps ensure electronic component stability and reliability by using the earth to absorb any static charge buildup or spurious signal noise that can affect the meter electronics. Earth ground in this installation is **NOT** the ground wire in the customer isolated power supply.

Process Fluid Grounding

Establishing a process fluid ground is one of the most important installation details. Proper process fluid grounding ensures that the sensor and fluid are at the same electrical potential so that only the induced flow signal is measured. The process fluid grounding provides a stable base potential reference for measuring the induced flow signal (the differential between the base potential reference and the fluid flow potential created by the sensor magnetic field). Process fluid grounding should be established on both sides (upstream and downstream) of the sensor elements.

By connecting the QSE sensor, the fluid, and the reference used by the internal electronics to a stable, noise free reference point (earth ground), the user is ensured of getting the best performance from their magnetic flowmeter.

Each QSE meter has a ground lug with a removable ring terminal located in the circular wall adjacent to the outlet end of the meter. This ground lug is connected internally to the electronics and sensors and is the meter connection to earth ground (the base potential reference).

Grounding Summary

1. Ground sensor to meter ground lug. (Done at factory.)
2. Ground electronics to meter ground lug. (Done at factory.)
3. Ground process fluid to meter ground lug (customer responsibility). Various process fluid grounding examples are shown on the following pages (see Figures 1, 2, and 3) to assist you in completing this item. The examples cover various meter installation situations.
4. Ground the meter ground lug to earth ground (customer responsibility).

All of the examples on the following pages show 14-16 AWG ground wire (customer supplied) being used. A ground wire should be crimped to the ring terminal on the meter ground lug and the other end of the ground wire connected to earth ground (item 4 above).

INSTALLATION (Continued)

**GROUNDING - Threaded Fittings - All Process Pipe Materials
Using GPI Grounding Probes (Kit P/N 145630-529)**

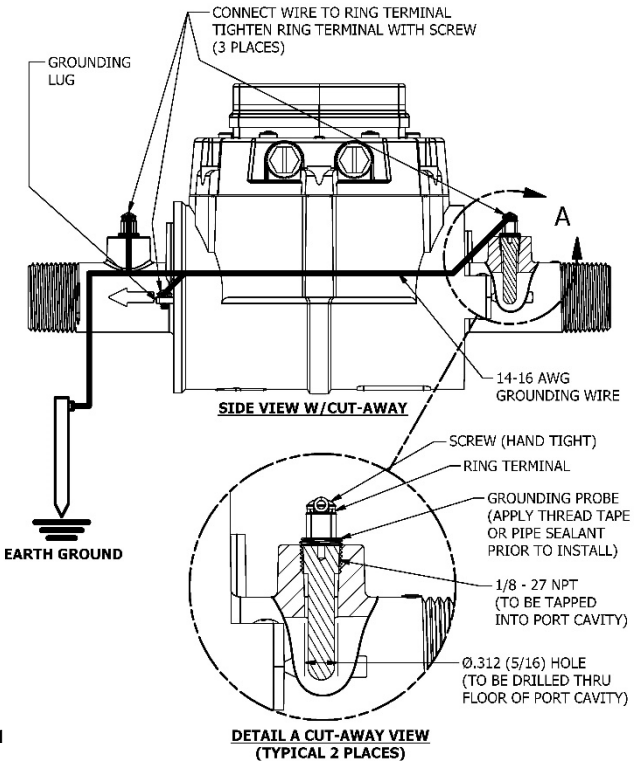

Figure 1

**GROUNDING - Threaded Fittings - Non-Conductive (Plastic) Pipe
Using Commercially Available Metal Couplings**

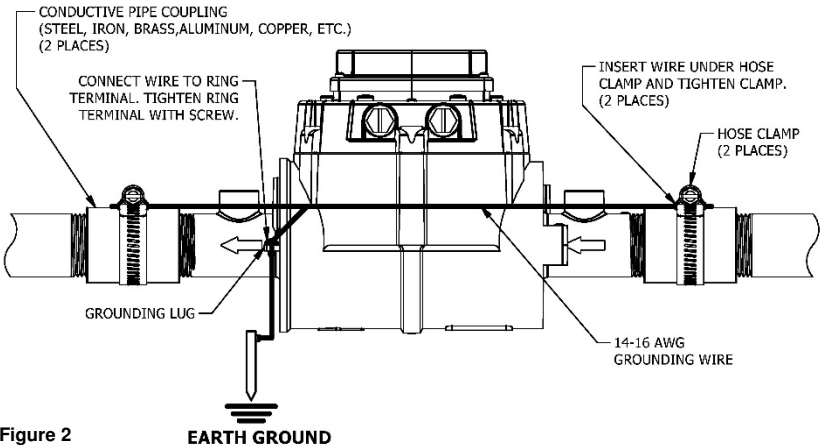

Figure 2

INSTALLATION (Continued)

**GROUNDING - ANSI Flange - Non-Conductive (Plastic) Pipe
Using Commercially Available Grounding Rings**

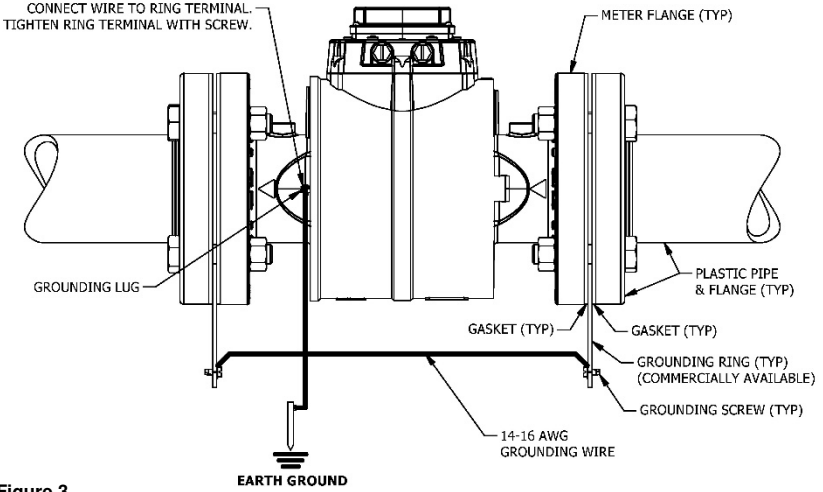

Figure 3

INSTALLATION (Continued)

Connections

Install your meter in-line with either horizontal flow or vertical flow. The best meter position for horizontal flow setups is with the meter rotated slightly (about 1 o'clock or 2 o'clock) to tilt the top from the horizontal plane (see Figure 4). This prevents sediment from settling on the lower set of sensing electrodes. Install the meter with the flow arrow pointing in the direction of fluid flow.

Plan to install meter with minimum straight pipe lengths at inlet and outlet ends. The straight run lengths noted below represent the minimum requirements for accurate flow measurement (see Figure 4). For optimum performance, provide as much additional straight run as possible.

- Upstream from the meter, allow a minimum straight pipe length of (5) times the pipe diameter from bends and obstructions.
- Downstream from the turbine, allow a minimum straight pipe length of (3) times the pipe diameter from bends and obstructions.
- Avoid downward flow that can lead to partially filled pipes

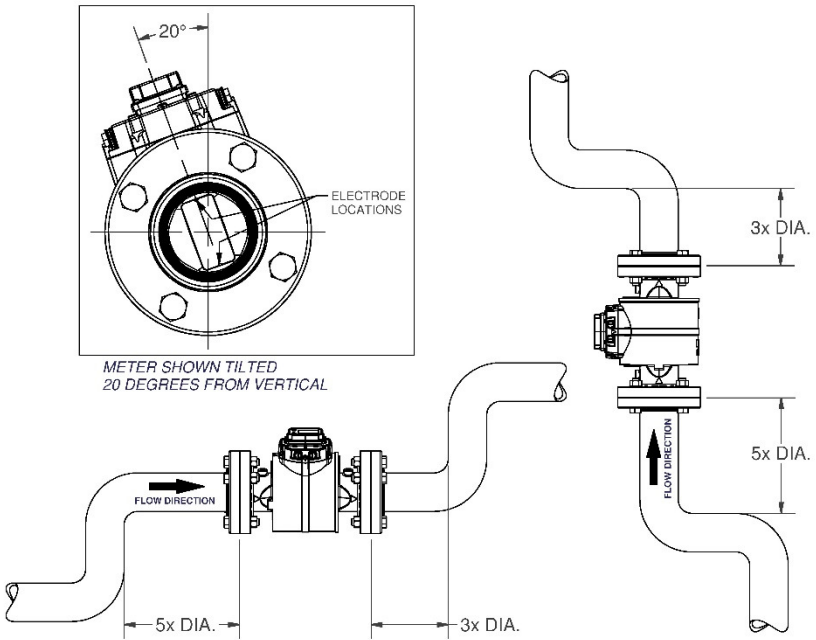

Figure 4

INSTALLATION (Continued)

NPT Fittings

Seal all pipe threads with an appropriate non-lubricated thread sealant (such as Loctite® No More Leaks™ Plastic Pipe Thread Sealant or NSF equivalent for NSF applications). Make sure the thread sealant does not intrude into the flow path. Hand tighten the meter at the housing ends. Do not use a wrench or similar tool to tighten as this can damage the housing.

NOTE: If connecting to new female pipe threads, burrs and curls can adversely affect accuracy. Correct the problem prior to meter installation.

BSPP Fittings

The BSPP meter includes a plastic bag containing (2) O-rings and (2) backup rings that must be installed onto the meter. They are used for sealing the fitting ends of the meter to process piping. Before installing the meter, install an O-ring in the O-ring gland on each housing end, then fit a backup ring over each O-ring (see Figure 5).

The BSPP meter is now ready for installation. Hand tighten the meter at the housing ends. **DO NOT** use a wrench or similar tool to tighten as this can damage the housing.

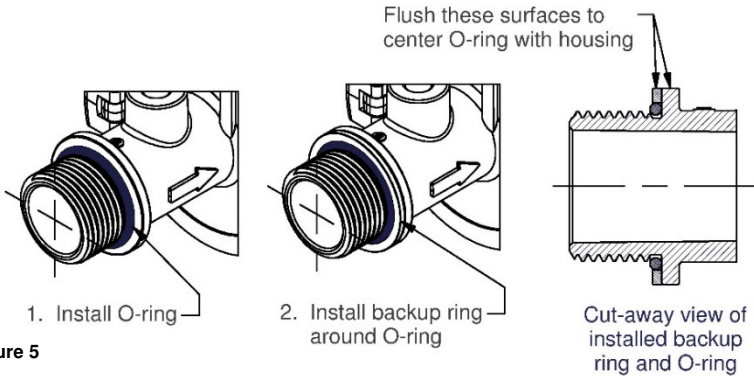

Figure 5

ANSI Flange Fittings

The flanges supplied with your meter allow the meter to be oriented regardless of the mating flanges position. The meter flanges and their steel half-ring “keys” must be installed onto the meter by the customer before meter installation (see Figure 6).

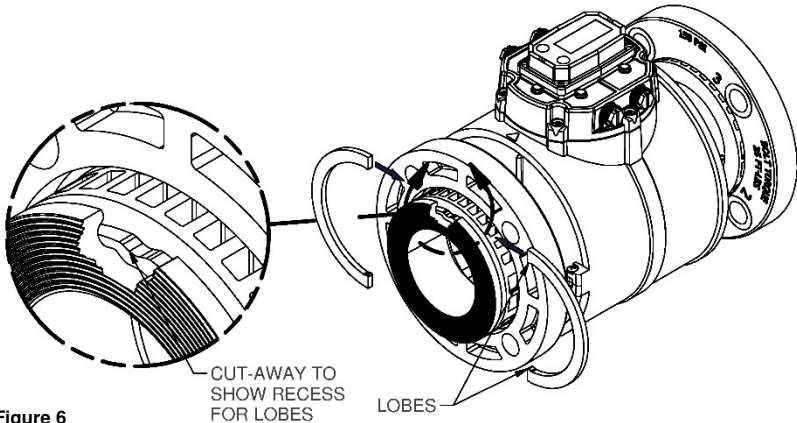

Figure 6

INSTALLATION (Continued)

Installing Flanges on Meter

With the mating face of the flange facing outboard, slide flange over one end of the meter. Position (2) half-rings in the retaining groove and snap into place. Each end of a half-ring has a small lobe that snaps into a recess at the top and bottom of the groove for retention. Repeat at other end.

Customer to Provide:

- Ring Gaskets or Full-Face Gaskets approved for use with type flange installed and the fluid being monitored (2 required).
- 5/8 in. bolts and nuts for ANSI flanges. Four per side for 3-inch meters; eight per side for 4-inch meters.
- Torque bolts using a star pattern to 25 ft-lbs (33.9 N•m). For best results, always verify torque accuracy before use.

NOTE: Do not over tighten the flange bolts. This may cause the gasket to be compressed into the flow stream and may decrease the accuracy of the meter.

When properly installed, the flow meter will only measure flow in that portion of the piping system where the meter is installed. Choose the location with the longest straight unobstructed run of pipe, keeping in mind that in some applications it may be possible to locate the meter in either the supply or return pipe.

NOTE: Your meter may have two 1/8 in. NPT pipe plugs installed on top of the flow tube near each end. They have been installed and sealed at the factory and are for use only with optional temperature sensing probes for energy use calculations in specialized applications.

WARNING: Compatibility of this product's material and the process fluid and/or environment should be considered prior to putting into service.

WARNING: Product should never be operated outside its published specifications for temperature or pressure. See specifications for your model.

WARNING: Make sure flow and pressure have been eliminated from process pipe prior to installing or removing product.

WARNING: When connecting product to process piping: For NPT fittings use non-lubricated thread sealant (such as Loctite® No More Leaks™ Plastic Pipe Thread Sealant or NSF equivalent for NSF applications). For BSPP fittings use O-ring seals. For flange fittings use flange gaskets.

CAUTION: Installation near high electromagnetic fields and high current fields is not recommended and may result in inaccurate readings.

CAUTION: Do not allow water to freeze in meter. Ice expansion may burst the plastic housing.

CAUTION: Do not allow this meter to be used with steam.

CAUTION: Piping should be properly supported to prevent undue structural stress on the meter body.

CAUTION: Pipe misalignment, especially metal pipe, can cause strain on plastic meter bodies resulting in permanent damage.

INSTALLATION (Continued)

Wiring

All electronic options are associated with a matching style of meter cover plate. This cover plate has four threaded ports, compatible with PG7 threads, for gaining wiring access to the electronics inside the cover plate. The meter is shipped with the ports environmentally sealed with a threaded plug and seal. Remove one or more of these plugs as required to install the supplied port fittings below.

Each meter is supplied with cable gland strain reliefs with O-rings and 1/2 NPT adapters with seals for use in the threaded ports of the meter cover plate. Select the port fittings that fit your process and replace the threaded plugs in the cover plate with the fittings as required. The threaded plugs installed at the factory may be left in any unused cover plate port indefinitely.

It is recommended that a "removable" thread-locker (fluid, stick, tape, spray, etc.) be used when installing the strain reliefs or adapters into the cover plate ports.

Strain Reliefs:

The cable gland strain reliefs will accommodate a cable diameter of 0.11 - 0.26 inches (2.79 - 6.6mm) and provide an environmental seal around the cable when the dome-nut is tightened.

NPT Adapters:

The 1/2 NPT adapter fittings are used for attaching flex conduit to the meter, for those applications that require cable runs to be enclosed in conduit.

- Cable to be provided by customer to accommodate job requirements. Cable is not included with meter.
- This meter is externally powered. The magnetic coils, electrodes and other electronic components within the main meter body receive power from the electronics housed within the cover plate. All external wiring connects to those cover plate electronics through threaded ports. See the included electronics manuals for meter wiring diagrams specific to this meters electronics.

TROUBLE SHOOTING

MEASUREMENT IS NOT ACCURATE	
PROBABLE CAUSE	SOLUTION
Debris/particles in liquid	Need proper filtration
Air in liquid - No back pressure	Increase back pressure on meter to eliminate air
Air in liquid - Plumbing installation	Install meter away from other fittings or flow obstructions. Do not allow meter to discharge to atmosphere.
Air in liquid - Pump cavitation	Install meter away from pump
Pipe not full - No back pressure	Increase backpressure on meter to eliminate air.
Pipe not full - Plumbing installation	Install meter where pipe is always full of liquid. Do not allow meter to discharge to atmosphere.
Conductivity of fluid too low	Consult liquid properties
Operating outside meter limits	Increase/decrease flow rate to proper meter specification. Review temperature limits.
Electrical noise	Install meter away from devices that emit EMF.
Ground loop	Meter may need to be earth grounded
Electrodes not clean	Clean electrode tips
Interface device not properly calibrated	Consult device instructions and specifications.
NORMAL FLOW BUT METER DOES NOT WORK	
PROBABLE CAUSE	SOLUTION
Wiring not correct	Consult wiring diagrams. Review installation.
Operating outside meter limits	Review voltage requirements
Meter installed backwards	Check to see if the direction of the arrows on the meter match flow direction.

MAINTENANCE

The meter is virtually maintenance-free. However, it is important to keep the meter clean and free of contaminants.

CAUTION: Do not allow liquids to dry inside the meter. The electrodes may develop a film that degrades accuracy.

Remove internal debris or deposits using soft brush or small probe.

NOTE: Make sure the arrow on the meter is pointed in the direction of fluid flow (see Figure 2).

SERVICE

For warranty consideration, contact your local distributor. If you need further assistance, contact the GPI Customer Service Department at:

1-888-996-3837

You will need to:

- Provide information from the decal on your meter.
- Receive a Return Authorization number.
- Flush any fluid from the meter before shipping to the factory.

CAUTION: Do not return the meter without specific authority from the GPI Customer Service Department. Due to strict regulations governing transportation, handling and disposal of hazardous or flammable liquids, GPI will not accept meters for rework unless they are completely free of liquid residue.



The Waste Electrical and Electronic Equipment (WEEE) directive (2002/96/EC) was approved by the European Parliament and the Council of the European Union in 2003. This symbol indicates that this product contains electrical and electronic equipment that may include batteries, printed circuit boards, liquid crystal displays or other components that may be subject to local disposal regulations at your location. Please understand those regulations and dispose of this product in a responsible manner.

RoHS Compliant (2011/65/EU)

This product is in compliance with the RoHS Directive of the European Parliament and of the Council on the Restriction of the Use of Certain Hazardous Substances in Electrical and Electronic Equipment.

ILLUSTRATED REPLACEMENT PARTS LIST

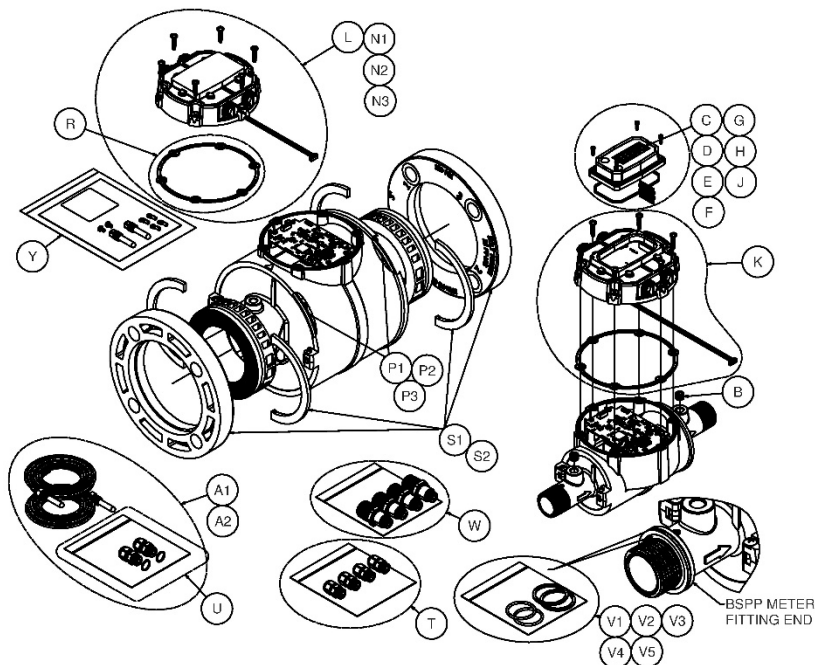

REF.	PART NUMBER	DESCRIPTION	NO REQ'D.
A1	145500-01	Kit, 1 in. temperature sensor probe Includes: (2) probes, (2) strain reliefs w/O-rings	1
A2	145500-02	Kit, 2 in. temperature sensor probe Includes: (2) probes, (2) strain reliefs w/O-rings.	1
B	145500-03	Kit, pipe plug, 1/8-27 NPT stainless steel Includes: (2) plugs.	1
C	145501-01	Kit, Q9 computer display, 1/2 in. Includes: Computer display w/decal, seal, 10-pin connector.	1
D	145501-02	Kit, Q9 computer display, 3/4 in. Includes: Computer display w/decal, seal, 10-pin connector.	1
E	145501-03	Kit, Q9 computer display, 1 in. Includes: Computer display w/decal, seal, 10-pin connector.	1
F	145501-04	Kit, Q9 computer display, 1-1/2 in. Includes: Computer display w/decal, seal, 10-pin connector.	1
G	145501-05	Kit, Q9 computer display, 2 in. Includes: Computer display w/decal, seal, 10-pin connector.	1

H	145501-06	Kit, Q9 computer display, 3 in. Includes: Computer display w/decal, seal, 10-pin connector.	1
J	145501-07	Kit, Q9 computer display, 4 in. Includes: Computer display w/decal, seal, 10-pin connector.	1
K	145500-14	Kit, QB w/display cover plate. Includes: Display cover plate, QB electronics with ribbon cable, (6) screws, cover plate seal.	1
L	145500-15	Kit, QB w/plain cover plate. Includes: Plain cover plate w/decal, QB electronics with ribbon cable, (6) screws, cover plate seal.	1
N1	145503-01	Kit, QSI1 w/plain cover plate. Includes: Plain cover plate w/decal, QSI1 electronics with ribbon cable, (6) screws, cover plate seal.	1
N2	145503-02	Kit, QSI2 w/plain cover plate. Includes: Plain cover plate w/decal, QSI2 electronics with ribbon cable, (6) screws, cover plate seal.	1
N3	145503-03	Kit, QSI3 w/plain cover plate. Includes: Plain cover plate w/decal, QSI3 electronics with ribbon cable, (6) screws, cover plate seal.	1
P1	145500-04	Kit, O-rings, For 1/2 in., 3/4 in. and 1 in. housings. Includes: (2) O-rings.	1
P2	145500-05	Kit, O-rings, For 1-1/2 in. and 2 in. housings. Includes: (2) O-rings.	1
P3	145500-06	Kit, O-rings, For 3 in. and 4 in. housings. Includes: (2) O-rings.	1
R	145500-07	Kit, seal, cover plate. Includes: (1) Cover plate seal.	1
S1	145500-08	Kit, ANSI flange, polymer, 3 in. Includes: (2) 3 in. polymer flanges, (4) 3 in. half-ring keys.	1
S2	145500-09	Kit, ANSI flange, polymer, 4 in. Includes: (2) 4 in. polymer flanges, (4) 4 in. half-ring keys.	1
T	145500-12	Kit, strain relief, cover plate. Includes: (4) PG7 thread strain reliefs, .11 - .26 cable diameter range	1
U	145500-13	Kit, strain relief, temperature sensor. Includes: (2) PG7 thread strain reliefs (reduced fit), .08 - .20 cable diameter range	1
V1	145500-20	Kit, O-ring & backup ring, 1/2 in. BSPP. Includes: (2) O-rings, (2) backup rings.	1
V2	145500-21	Kit, O-ring & backup ring, 3/4 in. BSPP. Includes: (2) O-rings, (2) backup rings.	1

V3	145500-22	Kit, O-ring & backup ring, 1 in. BSPP. Includes: (2) O-rings, (2) backup rings.	1
V4	145500-23	Kit, O-ring & backup ring, 1-1/2 in. BSPP. Includes: (2) O-rings, (2) backup rings.	1
V5	145500-24	Kit, O-ring & backup ring, 2 in. BSPP. Includes: (2) O-rings, (2) backup rings.	1
W	145500-25	Kit, PG7 to 1/2 NPT adapter, cover plate. Includes: (4) PG7 to 1/2 NPT male adapters	1
X	145177-501	Assembly, Ribbon Cable (9 INCH), Spare	1
Y	145630-529	Kit, grounding probe Includes: (2) grounding probes, (2) screws, (4) terminal rings, instruction sheet.	1

Great Plains Industries, Inc. 5252 E. 36th Street North, Wichita, KS USA 67220-3205, hereby provides a limited warranty against defects in material and workmanship on all products manufactured by Great Plains Industries, Inc. This product includes a 2-year warranty.

Manufacturer's sole obligation under the foregoing warranties will be limited to either, at Manufacturer's option, replacing or repairing defective Goods (subject to limitations hereinafter provided) or refunding the purchase price for such Goods theretofore paid by the Buyer, and Buyer's exclusive remedy for breach of any such warranties will be enforcement of such obligations of Manufacturer. The warranty shall extend to the purchaser of this product and to any person to whom such product is transferred during the warranty period.

The warranty period shall begin on the date of manufacture or on the date of purchase with an original sales receipt. This warranty shall not apply if:

- A. The product has been altered or modified outside the warrantor's duly appointed representative;
- B. The product has been subjected to neglect, misuse, abuse or damage or has been in- stalled or operated other than in accordance with the manufacturer's operating instructions.

To make a claim against this warranty, contact the GPI Customer Service Department at:

**316-686-7361 or 888-996-3837. Or by mail at:
Great Plains Industries, Inc.
5252 E. 36th St. North
Wichita, KS, USA 67220-3205**

The company shall, notify the customer to either send the product, transportation prepaid, to the company at its office in Wichita, Kansas, or to a duly authorized service center. The company shall perform all obligations imposed on it by the terms of this warranty within 60 days of receipt of the defective product.

GREAT PLAINS INDUSTRIES, INC. EXCLUDES LIABILITY UNDER THIS WARRANTY FOR DIRECT, INDIRECT, INCIDENTAL AND CONSEQUENTIAL DAMAGES INCURRED IN THE USE OR LOSS OF USE OF THE PRODUCT WARRANTED HEREUNDER.

The company herewith expressly disclaims any warranty of merchantability or fitness for any particular purpose other than for which it was designed.

This warranty gives you specific rights and you may also have other rights which vary from U.S. state to U.S. state.

Note: In compliance with MAGNUSON MOSS CONSUMER WARRANTY ACT – Part 702 (governs the resale availability of the warranty terms).



Wichita · Sydney

GREAT PLAINS INDUSTRIES



© 2020 Great Plains Industries, Inc., All Rights Reserved.

Great Plains Industries, Inc. / 888-996-3837 / flomecmeters.com